

LWQ GAS TURBINE FLOW METER

Summary

LWQ series gas turbine flowmeter integrates gas turbine flow sensor and flow converter. The main performance index reaches the international advanced level, and it is an ideal instrument for gas measurement of petroleum, chemical, electric power, metallurgy industry and civil boiler, city gas, gas pressure station measurement and gas trade measurement.



Product Features

- Use a new type of sensor, low starting flow, low pressure loss, good anti-vibration and anti-pulse fluidity, not easy to corrode, good reliability, and long service life.
- Adopt new micro-processing and high-performance integrated chips, with high calculation accuracy, powerful functions and superior performance.
- Use advanced micro-power high-tech, and the whole machine has low power consumption. It can not only run with internal battery for long-term power supply, but also can run with external power supply.
- According to the flow frequency signal, the instrument series can be divided into eight segments to automatically perform linear correction, and the calculation accuracy of the instrument can be improved according to user needs.
- Adopt EEPROM data storage technology. It has storage and query functions of historical data. There are three historical data recording methods for users to choose.
- The meter transmitter part can be rotated at 180°C, which is easy to install and use.
- High accuracy, generally up to $\pm 1.5\%R$, $\pm 1.0\%R$
- Good repeatability. Short-term repeatability can reach $0.05\%R \sim 0.2\%R$. Because of its good repeatability, it is the preferred flowmeter in trade settlement.
- It can detect the temperature, pressure and flow rate of the measured gas, automatically track and compensate the flow rate, and display the gas flow rate under the standard condition ($p_n=101.325kpa, T_n=293.15k$), and query the data of temperature, pressure, time and date in real time.

Operating Principle

Flow meter structure

The basic structure of the temperature and pressure compensated type gas turbine flowmeter is shown in the figure, which mainly consists of the meter body, movement (front guide, middle guide, rear guide), connection base and converter.

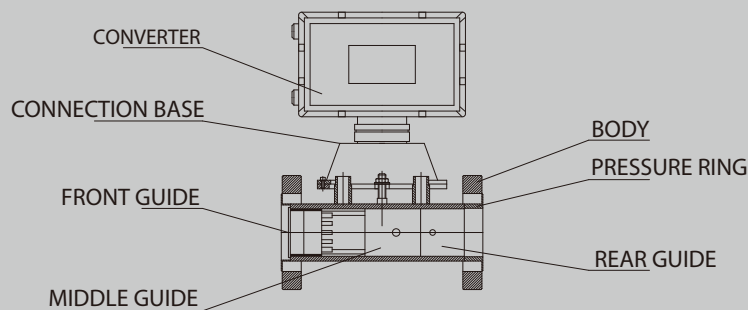

Gas Turbine Flow Meter Structure

Operating principle

When the airflow enters the flowmeter, it will first pass through the leading fluid of the independent movement and accelerate. The turbine blades are at a certain angle with the flow direction of the fluid. Under the action of the fluid, the turbine generates a rotational torque at this time. After the turbine overcomes the resistance torque and the friction torque, it starts to rotate. When the forces are balanced, the speed is stable, and the turbine rotation speed is linear with the flow rate. The magnet on the rotating transmitter plate periodically changes the sensor's magnetic resistance. Pulse signals proportional to the volume flow of the fluid are induced at both ends. The signal is amplified and reshaped by the preamplifier, and the pressure and temperature signals detected by the pressure and temperature sensor are simultaneously output to the flow totalizer for processing, which directly displays the standard volume flow rate and the standard volume total.

Working principle of flow totalizer

The flow totalizer is composed of a temperature and pressure detection analog channel, a flow sensor and a micro-processing unit, and is equipped with an external output interface to output various signals. The microprocessor in the flowmeter performs temperature compensation according to the gaseous equation and automatically corrects the compressibility factor. The gaseous equation is as follows:

$$Q_n = Z_n / Z_g (P_g + P_a) / P_n \cdot T_n / T_g \cdot Q_g$$

In the formula :

- Q_n —Volume flow in standard state(m^3 / h)
- Q_g —Uncorrected volume flow(m^3 / h)
- P_g —Gauge pressure at the pressure detection point of the flowmeter(KPa)
- P_a —Local atmospheric pressure(KPa)
- T_g —Absolute temperature of the medium($273.15 + t$) k
- t —Temperature of the measured medium($^{\circ}C$)
- Z_n —Compression coefficient in standard conditions
- Z_g —Coefficients for operating conditions
- T_n —Absolute temperature in standard conditions($293.15k$)
- P_n —Standard atmospheric pressure($101.325KPa$)

Note:

For natural gas $Z_n / Z_g = (F_z)^2$, F_z is called the super-compression factor and is calculated according to the formula in China National Petroleum Corporation's standard SY/T6143-4996.

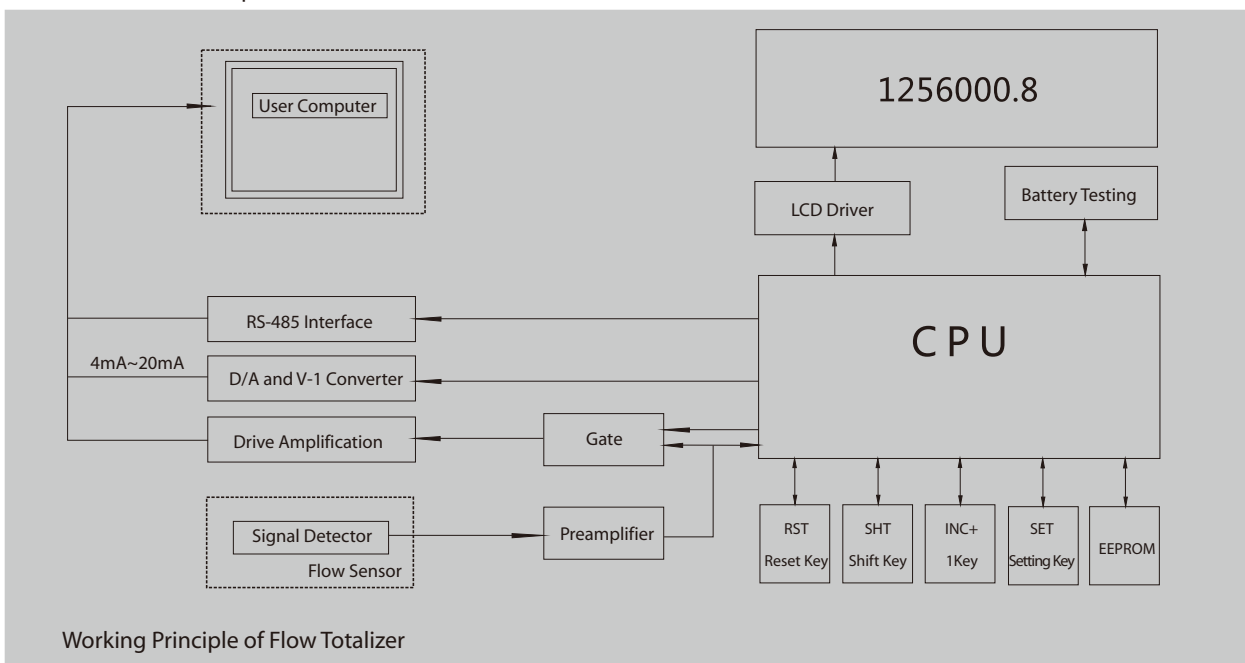

Technical Parameters

1. Basic Parameters

Executive standard	Measurement of gas flow in closed pipelines- turbine flow sensor (GB/T8940-2003)		
Instrument size (mm) and connection type	Flange connection type	Stainless steel	DN25-DN300
		Carbon steel	DN350, DN400
	Thread connection type	Carbon steel	DN25, DN40, DN50
Accuracy	±1.5%R (±1%R needs to be customized)		
Range ability	1:10 ; 1:20 ; 1:30		
Material construction	Body: SS304(DN25-DN300), CS(DN350 , DN400) Blade: Anti-corrosion ABS or high-quality aluminum alloy Conditioning plate: DN25-DN150 is ABS, DN200 is cast aluminum alloy Converter: Die-cast aluminum alloy		
Working condition	Ambient temperature: -20°C~+60°C	Relative humidity: 5%~90%	
	Medium temperature: -30°C~+80°C	Atmospheric pressure: 86kPa~106kPa	
Power supply	A. External power supply: +24VDC±15%, ripple < ±5%, applicable to 4-20mA output, pulse output, RS485, etc. B. Internal power supply: 1 set of 3.6V 10AH lithium battery, the battery voltage is 3.0V-3.6V for normal operation. Under voltage indication appears when the voltage is below 3.0.		
Overall power consumption	A. External power supply: < 2W B. Internal power supply: average power consumption < 800uA.		
Flange standard	Normal standard	GB/T 9113-2000	
	Other standards	International standard	DIN, ANSI, JIS
		China standard	HG, GB
Thread standard	Normal standard	BSP thread (male) (refer to GB/T7307-2001)	
	Other standards	Female thread, NPT thread, etc.	
Signal output	Pulse signal, 4-20mA current signal, Control signal		
Communication output	RS485 communication, Optional HART, GPRS		
Real-time recording	Start-stop record, daily record, fixed time interval record		
Signal line interface	Female M20X1.5 or other		
Ingress protection	IP65		
Explosion-proof	ExdIICT6 Gb		
Electrical Interface	M20*1.5 female thread (NPT thread on request)		

Typical error curve of flowmeter

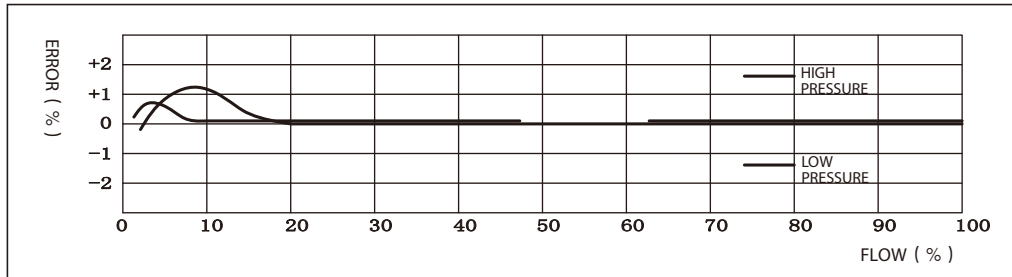

① Pulse output mode (select one of the following three by setting)

- A. Working condition pulse signal. Directly amplify and output the working condition pulse signal detected by the flow sensor through optocoupler isolation, high electrical level $\geq 20V$, low electrical level $\leq 1V$.
- B. The frequency signal proportional to the standard volume flow is isolated and amplified by the optocoupler. The high electrical level is greater than or equal to 20V, and the low electrical level is less than or equal to 1V.
- C. Calibration pulse signal is matched with IC valve controller. High electrical level $\geq 2.8V$, low electrical level $\leq 0.2V$. The unit pulse represents the volume settable range: $0.01m^3 \sim 10.00m^3$. But when selecting the value must be noted: the calibration pulse signal frequency should be $\leq 200Hz$.

② 4-20mA current signal (using optically isolated current module)

Proportional to the standard volume flow rate, 4mA for 0m³/h, 20mA for the maximum standard volume flow rate (this value can be set).

③ Control signal

- A. Lower limit alarm signal (LP): Photoelectric isolation collector (OC) output, normal state OC gate cut-off, alarm state OC gate conduction, maximum load 50mA current, power supply +12VDC ~ +24VDC.
- B. Upper limit alarm signal (UP): Photoelectric isolation collector (OC) output, OC gate is cut off in normal state, OC gate is on in alarm state, maximum load current 50mA, operating pressure is +12VDC~+24VDC.
- C. Turn off the alarm output (BC terminal, used for IC card controller): logic gate circuit output, normal output low electrical level, amplitude $\leq 0.2V$; alarm output high electrical level, amplitude $\geq 2.8V$, load resistance $\geq 100K \Omega$.
- D. Battery under voltage alarm output (for BL, IC card controller): logic gate circuit output, normal output low electrical level, amplitude $\leq 0.2V$; alarm output high electrical level, amplitude $\geq 2.8V$, load resistance $\geq 100K \Omega$.

④ RS485 Communication

Using RS485 interface, it can be directly connected to the host computer or secondary instrument, remotely display the temperature, pressure of the medium, and the standard volume flow and total standard volume after temperature and pressure compensation.

⑤ Real-time Recording Function

In order to meet the needs of data management, the flowmeter adds a real-time numerical control storage function, which can be set by one of the following three:

- a: Start/Stop record: The last 1200 start/stop times, total volume and net flow records. Factory default items.
- b: Daily records: Date record of the last 920 days. Temperature, pressure, standard volume and total volume record at zero time.
- c: Fixed time interval records: 1200 records of date and time, temperature, pressure standard volume and total flow rate at fixed time intervals. The above-mentioned stored data can be read through a laptop computer to form data reports and graphs for analysis.

2. Measuring Range and Working Pressure

Instrument Size (mm)	Model	Standard Range (m ³ /h)	Model	Extended Range (m ³ /h)	Normal Pressure Rating & Special High Pressure Rating		Mounting Type	Maximum Pressure Loss(KPa)
					(Mpa)	(Mpa)		
DN25	S	2.5-25	W	4-40	1.6	6.3, 4.0	Flange, Thread	1.5
DN40	S	5-50	W	6-60	1.6	6.3, 4.0	Flange, Thread	1.5
DN50	S1	6-65	W1	5-70	1.6	6.3, 4.0	Flange, Thread	0.5
	S2	10-100	W2	8-100	1.6	6.3, 4.0	Flange, Thread	1
DN80	S1	13-250	W	10-160	1.6	6.3	Flange	1
	S2	20-400			1.6	6.3	Flange	2.5
DN100	S1	20-400	W	13-250	1.6	6.3	Flange	1
	S2	32-650			1.6	6.3	Flange	1.5
DN150	S1	32-650	W	80-1600	1.6	4	Flange	1
	S2	50-1000			1.6	4	Flange	2
DN200	S1	80-1600	W	50-1000	1.6	4	Flange	0.5
	S2	130-2500			1.6	4	Flange	1
DN250	S1	130-2500	W	80-1600	1.6	2.5	Flange	0.5
	S2	200-4000			1.6	2.5	Flange	1.5
DN300	S	200-4000	W	13-2500	1.6	2.5	Flange	1
DN350	S	400-8000	W	320-6500	1.6	-	Flange	1.5
DN400	S	650-13000	W	650-13000	1.6	-	Flange	2

Notes:

1. DN20, DN32, DN65, DN125 are non-national standard products and need to be customized.
2. The maximum pressure loss is the pressure loss value of the flowmeter working at the maximum flow point, the medium is air, and it is at ambient temperature.

3. Instrument Classification

According to the function of the instrument, the LWQ series gas turbine flowmeter can be divided into 3 categories:

- ① Gas turbine flowmeter sensor/transmitter
- ② Intelligent display gas turbine flowmeter
- ③ Intelligent temperature and pressure compensation gas turbine flowmeter

4. Function Description

① Gas turbine flowmeter N/A type sensor/transmitter

The gas turbine flow sensor/transmitter product itself does not have the local display function, and only transmits the working condition flow signal remotely. The instrument is cheap, flexible and convenient, and small in size. It is especially suitable for use with secondary display, PLC, DCS and other computer control systems. This type turbine flowmeters are all explosion-proof products with an explosion-proof grade of ExdIICT6 Gb.



Display Type	No local display
Power Supply	DC24V, Ripple $\leq 5\%$
Signal Output	Pulse output' 4-20mA output
Explosion-proof	ExdIICT6 Gb

Application:

It can be used as a collection instrument of working condition flow signal, which can remotely transmit flow signal to the host computer.

② Intelligent display G type gas turbine flowmeter

The intelligent display G-type gas turbine flowmeter integrates a gas turbine flow sensor and a flow totalizer. Its main performance indicators have reached the domestic advanced level. It is used for gas metering in petroleum, chemical, electric power, metallurgical industry and boilers and urban natural gas pressure regulation. It is a ideal instrument for station metering and gas trade metering.



Display Type	Local display
Power Supply	DC24V, 3.6V lithium battery, 220V
Signal Output	Pulse output' 4-20mA output' RS485 output
Explosion-proof	ExdIICT6 Gb

Application:

It can be used for industrial control instrumentation in the field of stable pressure and temperature.

③ Intelligent display E-type gas turbine flowmeter

The intelligent display E-type gas turbine flowmeter integrates a gas turbine flow sensor and a flow totalizer. It has the characteristics of compact structure, high reliability, and no external power supply interference.

This type of turbine flowmeter has pulse output, 4-20mA current output, and RS-485 communication output mode can also be selected, which is suitable for use with secondary instrumentation, PLC, DCS and other computer control systems.



Display Type	Local display
Power Supply	DC24V, 3.6V lithium battery
Signal Output	Pulse output' 4-20mA output' RS485 output, HART
Explosion-proof	ExdIICT6 Gb

Application:

It can be used for industrial control instruments in the field of stable pressure and temperature.

④ Intelligent temperature and pressure compensation D2/D4 gas turbine flowmeter

The temperature and pressure compensation gas turbine flowmeter has built-in temperature and pressure sensors and an intelligent flow totalizer. Through the micro-processing unit, the real-time collected flow, temperature, and pressure signals are compensated for temperature and pressure according to the gas equation, and the compression factor is automatically corrected, and then the volume flow in the standard state is displayed intuitively.

※ Standard state flow rate: the gas volume flow rate under a standard atmospheric pressure at 20°C.



Display Type	Local display
Power Supply	DC24V, 3.6V lithium battery
Signal Output	Pulse output, 4-20mA output, RS485 output, IC card signal output, GPRS signal output
Explosion-proof	ExdIICT6 Gb

Application:

It can be used for industrial control instruments in the field of stable pressure and temperature.

Model Selection Table

1. Selection Instructions

When selecting the model, the user should reasonably select the model and specification of the flowmeter according to the nominal pressure of the pipeline, the highest pressure of the medium, the temperature of the medium, the condition of the medium composition, the flow range and the signal output requirements.

In order to maximize the performance of the flowmeter, the flow rate range of the flowmeter should be within the range of (20%~80%) Q_{max}. The signal output mode of the flowmeter when it leaves the factory: working condition pulse signal output (three-wire system), standard flow signal (IC card) output or RS-485 communication output. If other output functions are required, please specify when ordering.

2. Model Selection Table

Model										Contents
LWQ-	□	-□	-□	-□	-□	-□	-□	-□	-□	
Instrument Type	N									24V power supply, no local display, pulse output
	A									24V power supply, no local display, 4-20mA output
	G1									Local display, battery powered, no output
	GX									Local display, external power supply, current output/RS485 output/pulse output
	E1									Local display, battery powered, no output
	EX									Local display, external power supply, current output/RS485/pulse output
	D2									Temperature and pressure compensation type, dual power supply, RS485/current output/pulse output
	D4									Temperature and pressure compensation type, dual power supply, current output/RS485 output/pulse output
Nominal diameter	25									DN25
	40									DN40
	50									DN50
	80									DN80
	100									DN100
	150									DN150
	200									DN200
	250									DN250
	300									DN300
	350									DN350
	400									DN400
Connection Type	FL									Flange connection
	LW									Threaded connection
	Z									Special specification
Measuring Range	S									Standard range, please refer to Table 1 on page 2 for selection
	W									Extended range, please refer to Table 1 on page 2 for selection
	Z									Special range
Body Material	S									Stainless steel
	C									Carbon steel
Rotor Material	S									Anticorrosive ABS
	L									Aluminum alloy
Explosion-proof	N									Non explosion-proof
	E									ExdIICT6 Gb
Pressure Rating	N									1.6MPa
	H(x)									4-2High pressure refer to table 4-2
Accuracy	10									1%R
	15									1.5%R
	Z									Special accuracy requirement

Note:

DN20, DN32, DN65, and DN125 are non-national standard products and need to be customized.
X is a number, representing different functions, please consult the sales.

Outline Drawing and Installation Size

Intelligent Display Type Installation Size

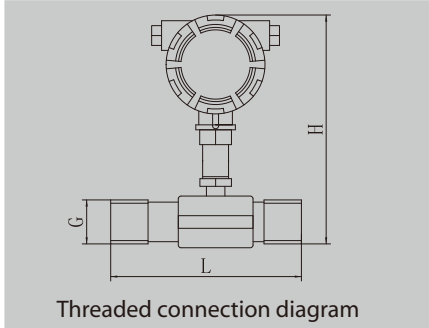

Instrument Size(mm)	L(mm)	H(mm)	G (Male Thread)
25	170	225	G2
40	200	225	G2
50	220	235	G 2 1/2

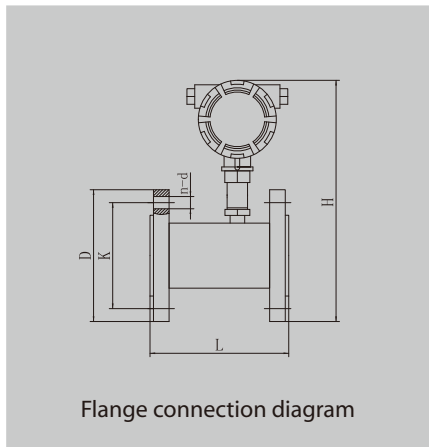

Instrument Size (mm)	L (mm)	D (mm)	K (mm)	H (mm)	d (mm)	n (Number of Holes)	Pressure Rating
25	200	115	85	255	14	4	1.6 MPa
40	200	150	110	275	18	4	
50	200	165	125	285	18	4	
80	240	200	160	320	18	8	
100	300	220	180	340	18	8	
150	450	285	240	400	22	8	
200	500	340	295	465	22	12	
250	500	405	355	525	26	12	
300	300	460	410	585	26	12	
350	350	520	470	640	26	16	
400	400	580	525	705	30	16	

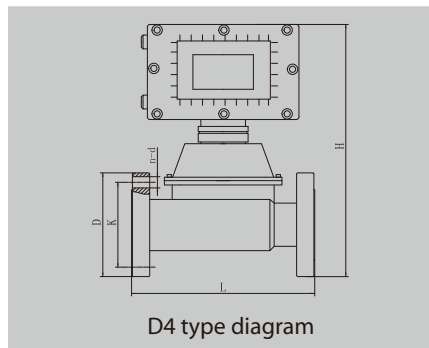

Instrument Size (mm)	L (mm)	D (mm)	K (mm)	H (mm)	d (mm)	n (Number of Holes)
25	200	115	85	349	14	4
50	200	165	125	405	18	4
80	240	200	160	425	18	8
100	300	220	180	455	18	8
150	450	285	240	530	22	8

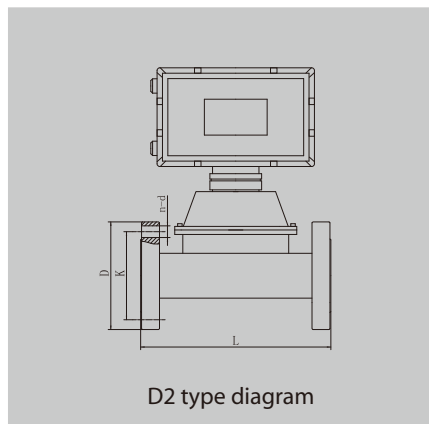

Instrument Size (mm)	L (mm)	D (mm)	K (mm)	H (mm)	d (mm)	n (Number of Holes)	Pressure Rating
25	200	115	85	330	14	4	1.6 MPa
40	200	150	110	355	18	4	
50	200	165	125	370	18	4	
80	240	200	160	400	18	8	
100	300	220	180	455	18	8	
150	450	285	240	485	22	8	
200	500	340	295	545	22	12	
250	500	405	355	605	26	12	
300	300	460	410	670	26	12	
350	350	520	470	730	26	16	
400	400	580	525	790	30	16	

External Installation Type

1. Installation of Flow Meter

The flowmeter should be installed horizontally. The flowmeter with a nominal diameter of 15~25mm and the pipe are connected by thread, and the flowmeter with a nominal diameter of 40~200 is connected with the pipe by a flange. The upstream straight pipe section of the flowmeter should be $\geq 10DN$, and the downstream straight pipe section should be $\geq 5DN$, (DN is the inner diameter of the pipe). When the fluid has particles and dirt, a filter should be installed on the upstream side of the flowmeter. When there is gas in the liquid fluid, a deaerator should be installed on the upstream side of the flowmeter. When the length of the straight pipe on the upstream side cannot be guaranteed, a direct-flow device should be installed. During installation, a bypass pipeline should be laid for easy cleaning and replacement, see the figure below.

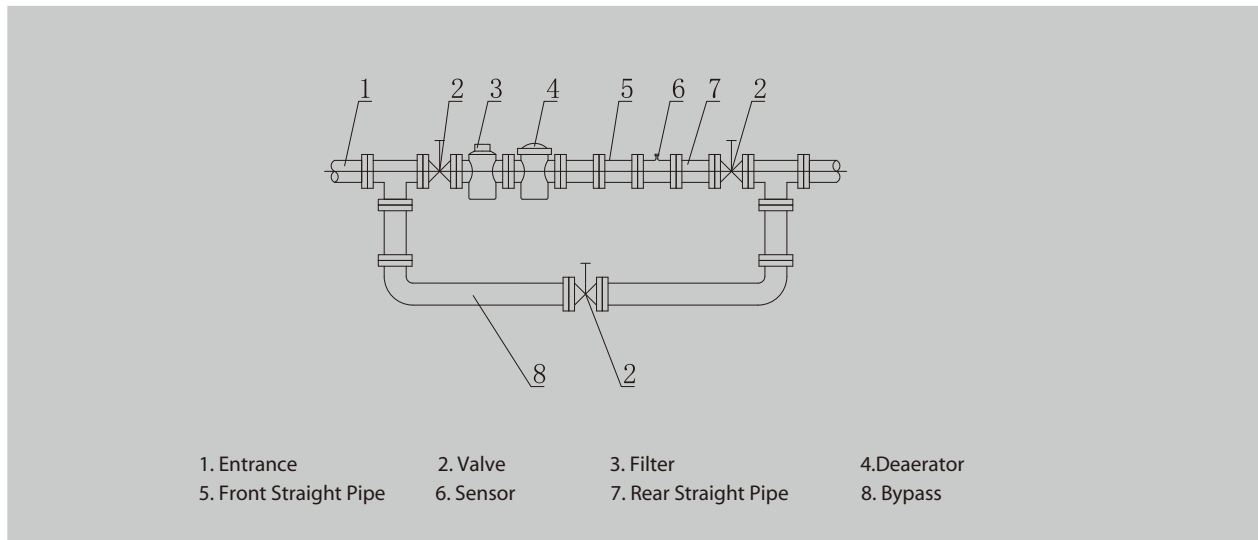

2. During installation, the liquid flow direction should be consistent with the direction of the arrow indicating the flow direction on the flowmeter housing.
3. The flowmeter should be far away from the external electromagnetic field. If it cannot be avoided, the necessary shielding measures should be taken.
4. The liquid flowing in the pipeline must not contain magnetically conductive substances.

Ordering Information

When ordering, please read this selection sample first, and select the appropriate flowmeter according to the fluid medium condition and site requirements, and then provide the manufacturer with the following information.

- The model of the gas turbine flowmeter
- The name of the fluid medium and its physical parameters
- Maximum working pressure Maximum working temperature Minimum working temperature
- Common flow rate Maximum flow rate Minimum flow rate